

DC Power Jack

(04-915) Series

Voltage classification II

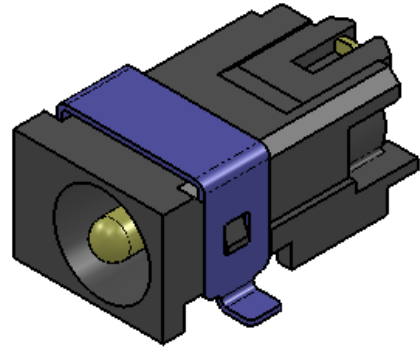

04-915A0-02BKA

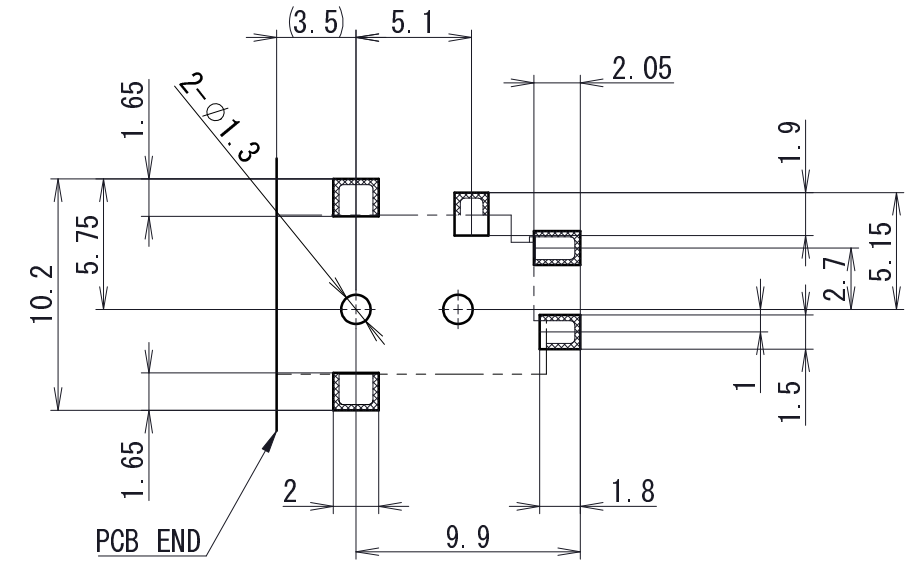
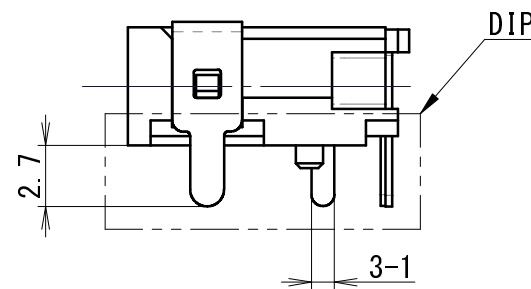
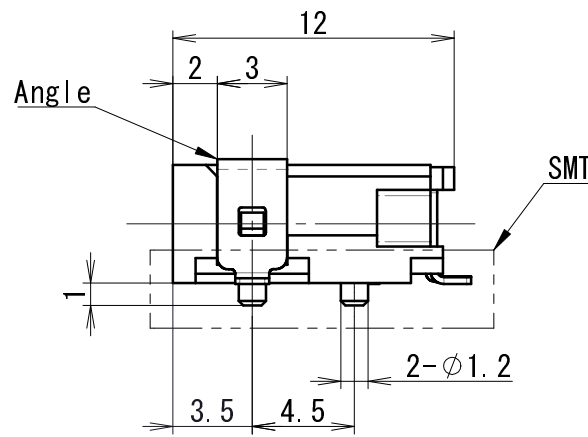
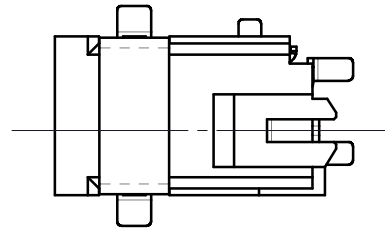
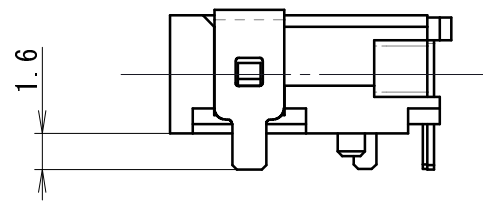
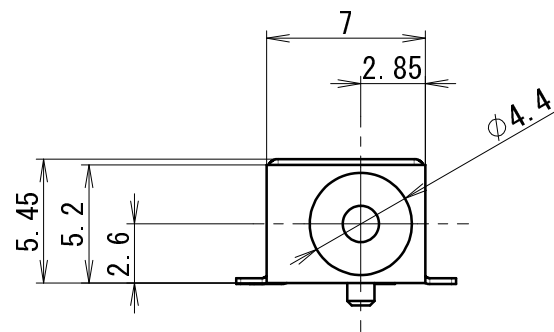

PCB Layout (SMT)
(Top View)

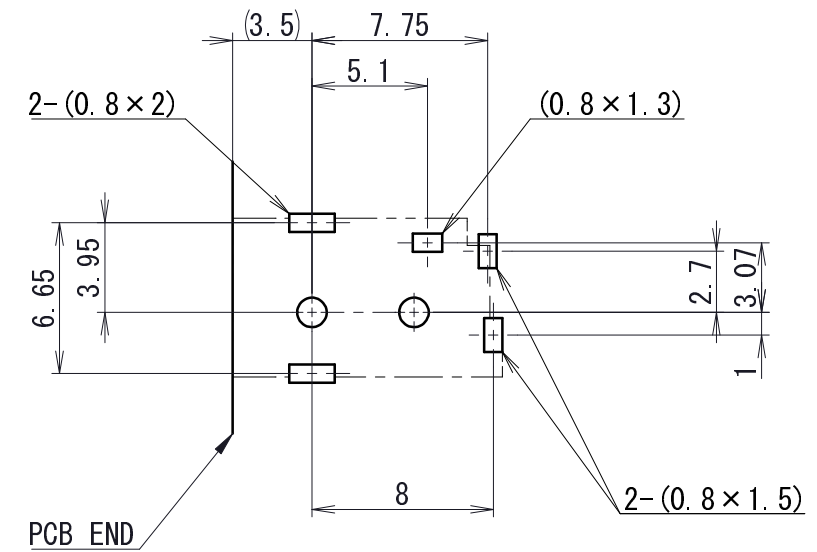

PCB Layout (DIP)
(Top View)

※The back same dimension

Part No.	04-915A0-02BKA	04-915C0-02BKA	04-915G0-02BKA	04-915H0-02BKA
Schematic				
Mounting style	SMT	DIP	SMT	DIP
Angle	Yes	Yes	No	Yes